

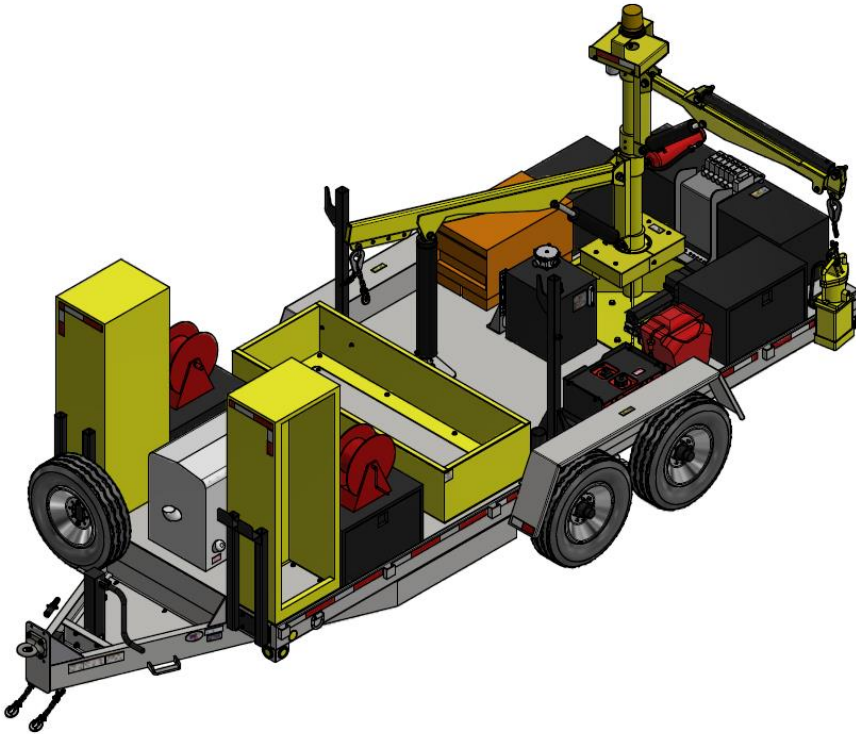

Highway Guardrail Maintenance Trailer

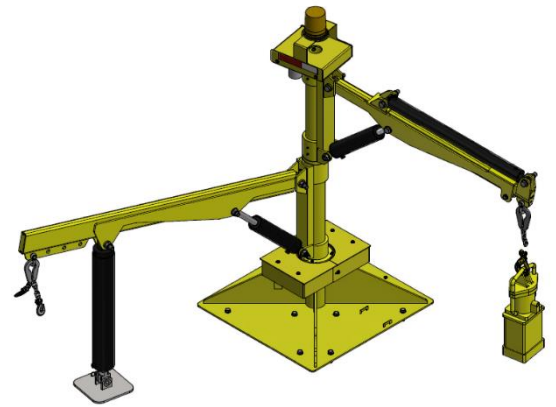

The Viking-Cives Highway Guardrail Maintenance Trailer is designed to remove and replace guardrail posts as a standalone unit. All power sources for hydraulic and pneumatic functions are contained on the unit, eliminating the need for a dedicated truck to perform these operations.



Frame – 18' deck constructed of 8x2x1/4 rectangular tubing with ten 3x4.1 cross members and two 3x2x1/4 rectangular tubing for cross members under the puller/hammer. The deck is built from 3/16" thick steel plate and is located 28" from the ground.

Axles – Two 8,000 lb. axles with a wheel base of 36 3/4" giving the trailer a GVWR of 16,000 lbs. The axles are also equipped with electric brakes.

Storage Includes:

- (2) 18x23x65 Flammable Lockers
- (3) 18x18x30 Toolboxes
- (1) 18x18x24 Toolbox
- (1) 18x18x60 Toolbox
- (1) 18x18x32 Tool chest

These tool boxes provide 69.77 cubic feet of dry storage. In addition, there is a 16x32x78 post storage box.

Vanair Air Compressor:

- Rotary screw compressor
- 26.5 HP gas motor
- Produces 80 cfm at 100 psi
- Load adjusting motor (Max rpm of 3600 and minimum of 2500)
- 2 50 ft long 3/4" hose reels

Honda V-Twin Gas Engine:

- 20.8 HP motor
- 35.6 ft.lbs. of torque
- 3600 max rpm
- 9 Gallon marine gas tank

Hydraulics:

- 6 Slice valve block to control booms from rear of trailer
- 2-stage hydraulic pump capable of 11.94 gpm at 3600 rpm
- 25 gallon hydraulic tank

Puller/Hammer Booms:

- 2 Independent 360° rotating booms rated at 500 lb. each
- Lower boom moves a 30" stroke x 5" bore pulling cylinder rated for 3000 psi
- Upper boom has the ability to extend and retract 36"
- PD-140 Rhino Air Pounder
- Top of mast (Including light) is 10' from the ground

Viking-Cives (USA)
14331 Mill Street
Harrisville, NY 13648
315-543-2321 Phone
315-543-2366 Fax

Viking-Cives Ltd.
P.O. Box 1120 RR#4
Mount Forest, ON N0G 2L0
519-323-4433 Phone
519-323-4608 Fax

Viking-Cives Midwest
P.O. Box 295 22956 Hwy 61
Morley, MO 63767
573-262-3545 Phone
573-262-3540 Fax