

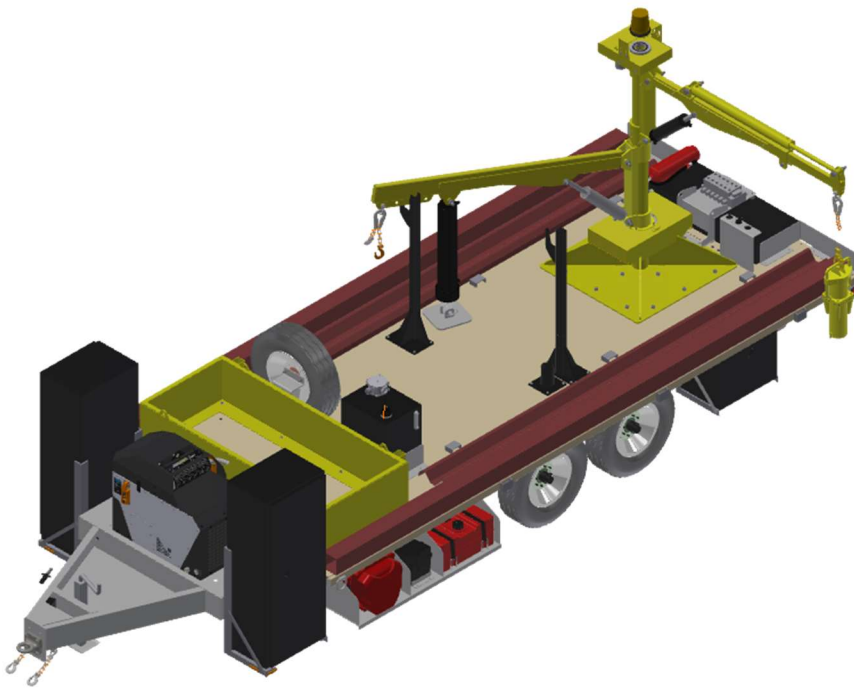

Highway Guardrail Maintenance Trailer

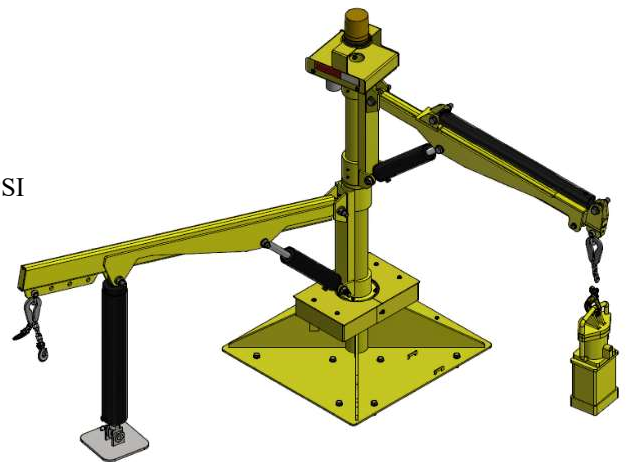

The Viking-Cives Highway Guardrail Maintenance Trailer is designed to remove and replace guardrail posts as a standalone unit. All power sources for hydraulic and pneumatic functions are contained on the unit, eliminating the need for a dedicated truck to perform these operations.



Frame:

- 18'6" deck constructed of 8"x2"x1/4" rectangular tubing
- (10) 3" cross members
- (2) 3"x2"x1/4" rectangular tubing cross members under the crane
- 1/4" thick steel plate deck, located 35" above the road surface

Axles:

- (2) 8,000 lb. axles with a spread of 36 3/4"
- GVWR of 16,000 lbs.
- Axles are equipped with electric brakes

Storage:

- (2) 18"x24"x60" flammable storage lockers
- (1) 18"x18"x48" toolbox
- (2) 18"x18"x24" boxes
- (1) 18"x18"x60" toolbox
- 59.25 cubic feet of dry toolbox storage in total
- 16"x32"x78" post storage bin also included

Vanair Compressor:

- Rotary screw compressor
- 26.5 HP gas motor
- Produces 80 CFM at 100 PSI
- Load adjusting motor (3600 RPM max. & 2500 RPM min.)
- 100' long 3/4" hose reel

Honda V-Twin Gas Engine:

- 20.8 HP motor
- 35.6 ft./lbs. of torque
- 3600 max rpm
- 9 Gallon marine gas tank

Hydraulics:

- (6) bank valve assembly to control booms from rear area of trailer
- 2-stage hydraulic pump capable of 11.94 GPM at 3600 RPM
- 25-gallon hydraulic tank

Puller & Pounder Booms:

- (2) independent 360° rotating booms rated at 500 lb. each
- Lower boom moves a 30" stroke x 5" bore pulling cylinder rated for 3000 psi
- Upper boom can extend and retract up to 36" to locate the pounder precisely where it is needed
- Rhino PD-140 pneumatic post pounder
- Top of mast (including light) is 10' above the road surface

Viking-Cives (USA)
14331 Mill Street
Harrisville, NY 13648
315-543-2321 Phone
315-543-2366 Fax

Viking-Cives Great Lakes
1405 Shiga Drive
Battle Creek, MI 49307
269-288-4010 Phone
269-288-4099 Fax

Viking-Cives Ltd.
P.O. Box 1120 RR#4
Mount Forest, ON N0G 2L0
519-323-4433 Phone
519-323-4608 Fax

Viking-Cives Midwest
P.O. Box 295 22956 Hwy 61
Morley, MO 63767
573-262-3545 Phone
573-262-3540 Fax